

Tough, abrasion-resistant polyethylene with thick aggressive adhesive for areas where tubing can not be applied.

Heat Shrinkable Polyolefin Tape

Product Number IP69HT

Heat shrinkable polyolefin tape is a primerless, heat shrinkable tape designed to insulate and seal areas, where tubing can not be used, for protection against moisture and corrosion. This unique tape permits quick and reliable installation without error by installers who have little experience working with heat shrink products. The shrinking action achieves exceptional conformation to contours, squeezing the adhesive into all surface irregularities, forming an effective seal.

Using a propane torch or heat gun, pre-heat the object to remove any moisture. This will assist flow-out and bonding of the adhesive. Spirally wrap tape, keeping snug at all times, with about a 20% overlap. Warm the ends first and press down firmly to secure. Start shrinking from the center, moving in a circular direction around the pipe at all times. As the tape shrinks, work towards the ends of the tape.

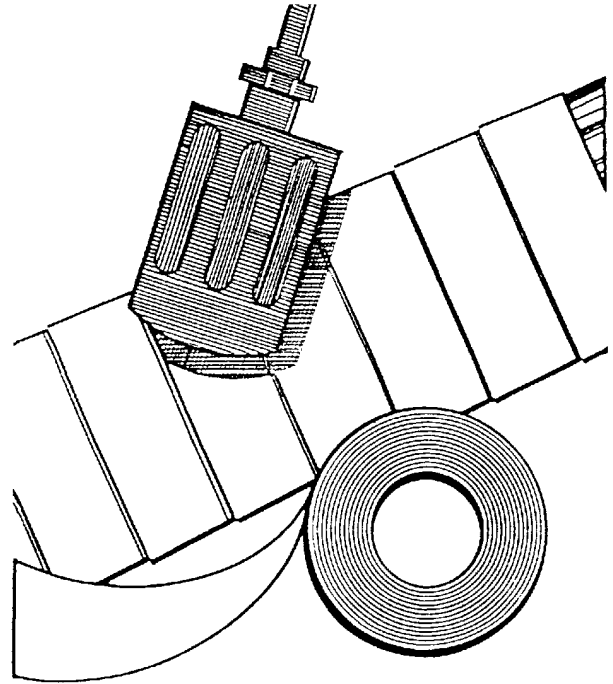

Specifications:

Standard Size

3/4"
1"
1-1/2"
2"
3"
4"
6"

50' lengths

Temperature Rating		-25°C to 60°C
Tape Tensile Strength	ASTM D-638	2,600 P.S.I.
Tape Elongation	ASTM D-638	600 P.S.I.
Adhesive Softening Point	ASTM E-28	76°C
Adhesive Peel Strength		10 P.S.I.
Adhesive Lap Shear Strength		25 P.S.I.
Low Temperature Flexibility	ASTM D-2671	-25°C
Water Absorption	ASTM D-570	0.15% after 24 hrs at 23°C
Volume Resistivity	ASTM D-257	10 ¹⁵ OHM-CM
Dielectric Breakdown	ASTM D-149	650 volts/mil
Tape Backing Thickness		.016"
Adhesive Thickness		.035"